

1. LAY TOP ASSEMBLY TOP DOWN , ON A FLAT CLEAN SURFACE.
2. CENTER AND ATTACH CENTER CHANNEL, USING 6 BOLT CLIP ASSEMBLIES.
3. ATTACH DIAGONAL BRACES TO CENTER USING 1-1" HEX HEAD CAP SCREW.
4. ATTACH END FRAMES TO DIAGONAL BRACES USING 1" HEX HEAD CAP SCREWS.
5. SQUARE END FRAMES AND ATTACH TO TOP USING BOLT CLIP ASSEMBLIES.
6. ATTACH SEAT PLANKS, USING 4 - BOLT CLIP ASSEMBLIES.
7. TIGHTEN ALL HARDWARE.

ITEM	QTY	PART NO.	DESCRIPTION
1	2		END SUPPORT FRAME
2	2		30" DIAGONAL BRACE (5' & 6')
3	1		23" CENTER CHANNEL
4	26		1 1/4" X 5/16" CARRIAGE BOLTS
5	29		5/16" SERRATED FLANGE NUTS
6	26		BOLT CLIPS
7	3		1" X 5/16" HEX HEAD CAP SCREWS
8	2		2 X 10 X 70" ALUMINUM SEAT PLANKS
9	1		2 X 28" X 70" ALUMINUM TOP PLANK
	2		39" DIAGONAL BRACE (7' & 8')

- LENGTH OPTION**
- 5' TABLE
- 6' TABLE
- 8' TABLE
- STEEL OPTIONS**
- PAINTED
- FRAME COLOR OPTIONS**
- BROWN
- GREEN
- HOT DIPPED GALVANIZED
- TOP AND SEATS**
- SILVER ANODIZED ALUMINUM

SCALE: NONE
 DATE DRAWN: 3-18-08
 DRAWN BY: CHG
 DATE REVISED: 3-23-09
 REVISED BY: CHG

GERBER MFG., LTD. 
 2917 LATHAM DRIVE - MAIDSON, WI 53713
1-800-393-9923

PICNIC TABLE ASSEMBLY
 ALUMINUM
 11S SERIES
 5', 6' AND 8' ALUMINUM

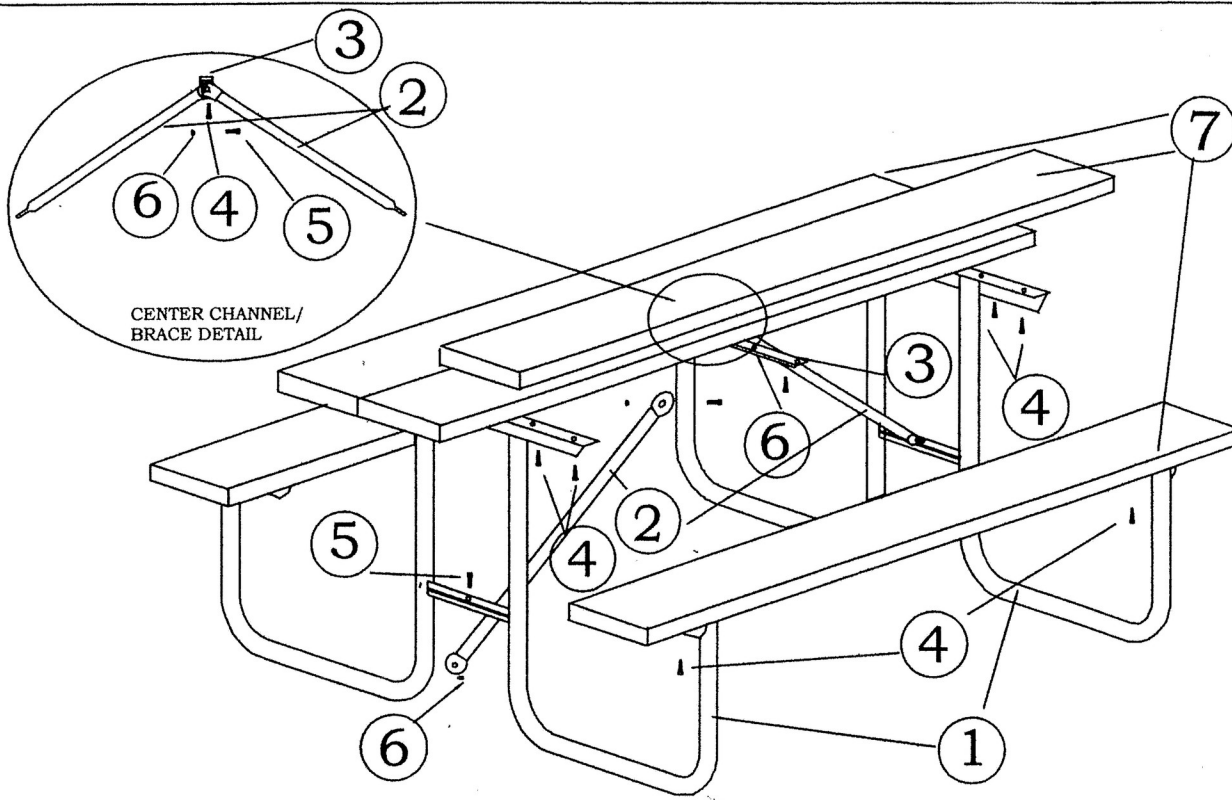

1. LAY 3 - 2 X 10 BOARDS, GOOD SIDE DOWN, ON A FLAT CLEAN SURFACE.
2. SQUARE BOARDS AND SPACE ABOUT 1/4" APART.
3. CENTER, CENTER CHANNEL AND ATTACH WITH 10 - 1 1/4" LAG SCREWS.
4. ATTACH DIAGONAL BRACES, USING 1 - 1" BOLT.
5. ATTACH END FRAMES TO DIAGONAL BRACES USING 2 - 1" BOLTS.
6. SQUARE AND CENTER END FRAMES AND ATTACH FRAMES TO BOARDS, USING 24 - 1 1/4" LAG SCREWS.
7. CENTER AND ATTACH 2 X 10 SEAT BOARDS TO FRAMES USING 12 - 1 1/4" LAG SCREWS.

NOTE: LAG SCREWS ARE SELF TAPING AND REQUIRE NO PRE-DRILLING OF LUMBER.

ITEM	QTY	PART NO.	DESCRIPTION
1	2	200247	END SUPPORT FRAME
2	2	200195	30" DIAGONAL BRACE (5' & 6')
3	1	200152	23" CENTER CHANNEL
4	46	200239	1 1/4" X X 1/4" LAG SCREWS
5	3	200231	1" X 5/16" HEX HEAD CAP SCREWS
6	3	200230	5/16" SERRATED FLANGE NUTS
7	5	200335	2 X 10 X 70" #1 SOUTHERN PINE
	2	200201	39" DIAGONAL BRACE (7' & 8')

- LENGTH OPTION**
- 5' TABLE
- 6' TABLE
- 8' TABLE

- COLOR OPTIONS**
- BROWN
- GREEN

- HARDWARE**
- LAG SCREWS

- STEEL OPTIONS**
- PAINTED
- HOT DIPPED GALVANIZED

- WOOD OPTIONS**
- #1 SOUTHERN PINE
- #1 ACQ TREATED SOUTHERN PINE

SCALE:	NONE
DATE DRAWN:	4-19-06
DRAWN BY:	CHG
DATE REVISED:	4-20-06
REVISED BY:	CHG

GERBER MFG., LTD.

2917 LATHAM DRIVE - MAIDSON, WI 53713

1-800-393-9923

PICNIC TABLE ASSEMBLY
LAG SCREWS

11S SERIES
5', 6' AND 8' LUMBER

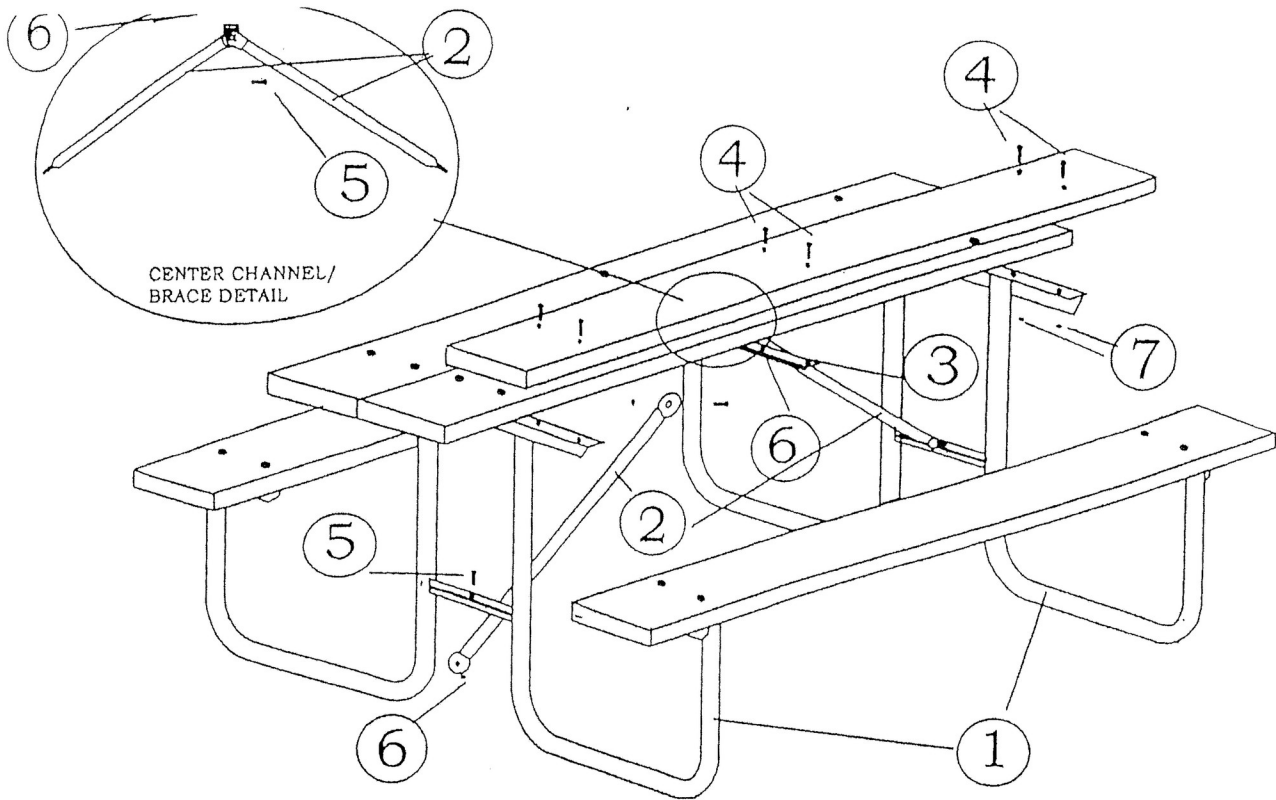

1. LAY 3 - PLANKS, GOOD SIDE DOWN, ON FLAT CLEAN SURFACE WTH 2" CARRIAGE BOLTS INSERTED. NOTE: PLANKS ARE MARKED: "R" RIGHT TOP, "C" CENTER TOP, "L" LEFT TOP, "S" SEAT BOARDS.
2. ATTACH END FRAMES, USING 12 - 2" BOLTS.
3. ATTACH CENTER CHANNEL, USING 6 - 2" BOLTS.
4. ATTACH DIAGONAL BRACES, USING 3 - 1" BOLTS.
5. ATTACH SEAT PLANKS, USING 4 - 2" BOLTS. THE "S" SHOULD BE ON THE SAME END AS "R" "C" "L".
6. TIGHTEN ALL HARDWARE.

NOTE:

- IF YOU HAVE PURCHASED THE LUMBER LOCALLY OR FROM US, NOT DRILLED, AND ARE USING CARRIAGE BOLTS PRE-DRILL AS FOLLOWS:
- A1. LAY 3 - PLANKS, GOOD SIDE DOWN SPACED 1/4" APART ON A FLAT CLEAN SURFACE.
 - A2. PRE ASSEMBLE THE FRAME, BRACES AND CENTER CHANNEL. SET UPSIDE DOWN ON THE LUMBER, SQUARE AND CENTER, AND MARK 2 HOLES IN EACH END OF THE BOARDS. ALSO MARK 2 HOLES IN EACH BOARD FOR THE CHANNEL.
 3. MARK AND DRILL FOR SEAT BOARDS.
 4. ASSEMBLE TABLE PER ABOVE INSTRUCTIONS.

ITEM	QTY	PART NO.	DESCRIPTION
1	2	200100	END SUPPORT FRAME
2	2	200195	30" DIAGONAL BRACE (5' & 6')
3	1	200152	23" CENTER CHANNEL
4	26	200226	2" X 1/4" CARRIAGE BOLTS
5	3	200231	1" X 5/16" HEX HEAD CAP SCREWS
6	26	200230	5/16" SERRATED FLANGE NUTS
7	3	200238	1/4" SERRATED FLANGE NUTS
8	5	200335	2 X 10 X 70" #1 SOUTHERN PINE
	2	200201	39" DIAGONAL BRACE (7' & 8')

LENGTH OPTION

- 5' TABLE
 6' TABLE
 8' TABLE

COLOR OPTIONS

- BROWN
 GREEN

HARDWARE

- CARRIAGE BOLTS

STEEL OPTIONS

- PAINTED
 HOT DIPPED GALVANIZED

WOOD OPTIONS

- #1 SOUTHERN PINE
 #1 ACQ TREATED SOUTHERN PINE

SCALE:	NONE
DATE DRAWN:	3-28-06
DRAWN BY:	CHG
DATE REVISED:	4-20-06
REVISED BY:	CHG

GERBER MFG., LTD. 

2917 LATHAM DRIVE - MAIDSON, WI 53713

1-800-393-9923

PICNIC TABLE ASSEMBLY
CARRIAGE BOLTS

11S SERIES
5', 6' AND 8' LUMBER

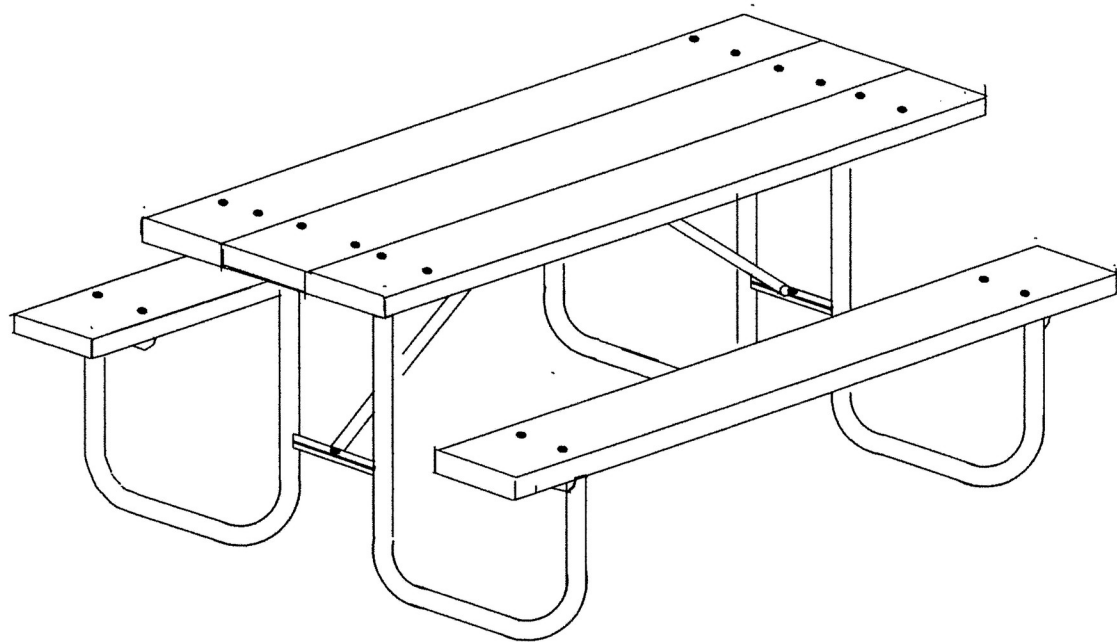
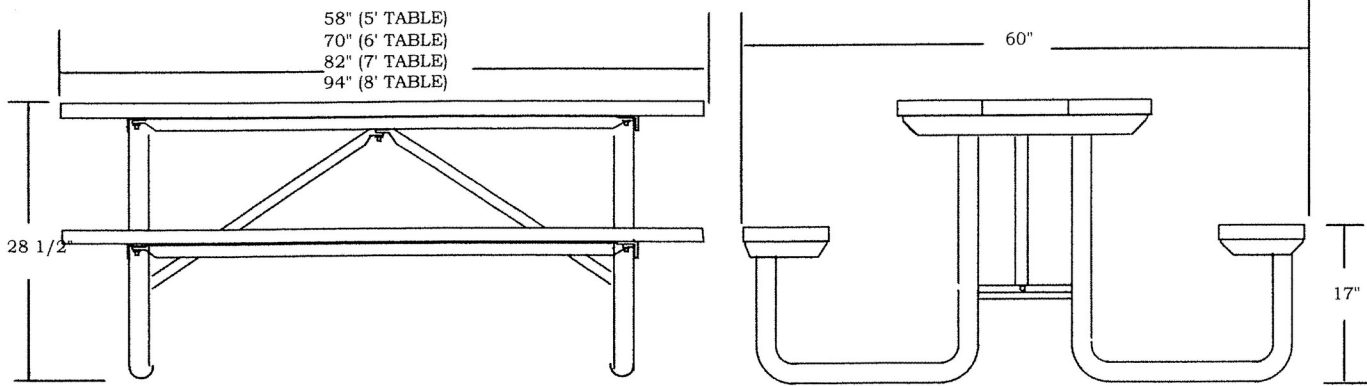

END SUPPORT FRAMES:
 1 1/2" OD 11 GAUGE STEEL TUBING
SEAT AND TOP SUPPORTS
 1 3/4" X 1 3/4" X 3/16" STEEL ANGLE
LEG TIE SUPPORT
 1" X 1" X 1/8" STEEL ANGLE
DIAGONAL BRACE
 16 GAUGE X 1 1/4" O.D. STEEL TUBE
SUPPORT TUBES
 16 GAUGE X 1 1/4" O.D. GALVANIZED STEEL TUBE
HARDWARE:
 STAINLESS STEEL
 FRAME, CHANNEL, BRACE FINISH
 PAINTED OR HOT DIPPED GALVANIZED
PLANKS: HIGH-DENSITY POLYETHYLENE MATERIAL
 DERIVED FROM POST CONSUMER BOTTLES.

SCALE:	NONE
DATE DRAWN:	9-24-08
DRAWN BY:	CHG
DATE REVISED:	
REVISED BY:	

GERBER MFG., LTD. 
 2917 LATHAM DRIVE - MAIDSON, WI 53713
1-800-393-9923

PICNIC TABLE
 SPECIFICATIONS
11S-PL SERIES
 5, 6' 7' & 8' RECYCLED PLASTIC